

**MODEL 1820**

# HORIZONTAL CUTTER

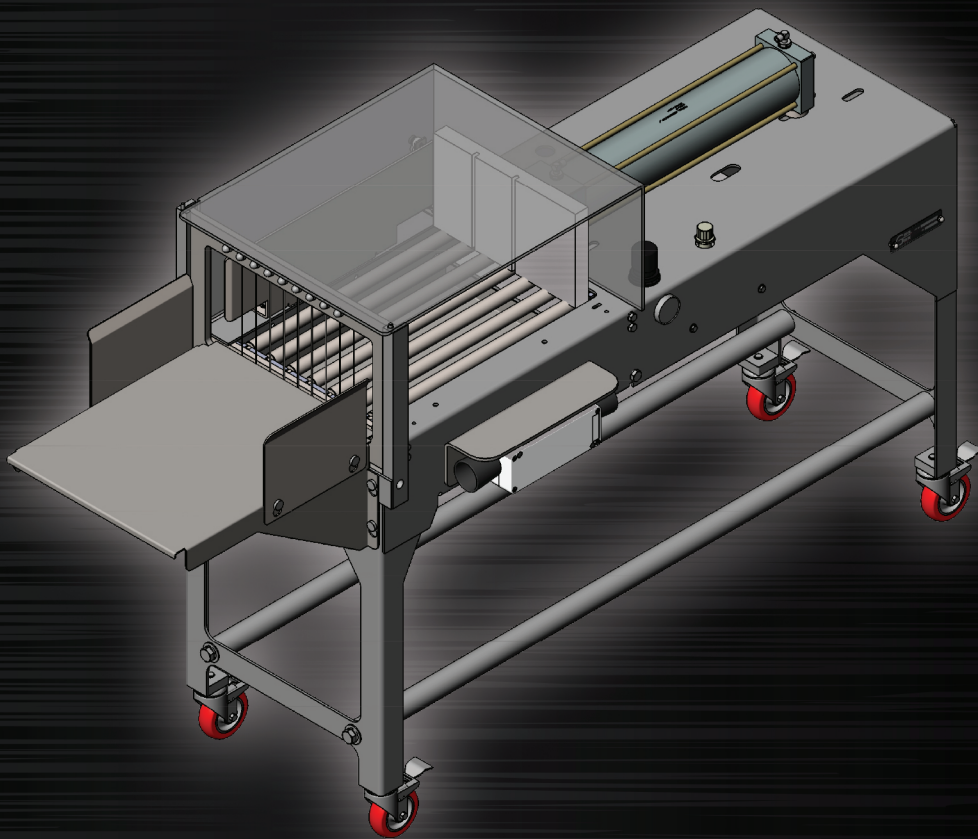

**GENMAC**

*A Division of 5 Point Fabrication, LLC.*  
1680 Cornell Road | Green Bay, WI 54313

PHONE (920) 458-2189

FAX (920) 458-8316

EMAIL [Sales@genmac.com](mailto:Sales@genmac.com)



# MODEL 1820

## HORIZONTAL CUTTER

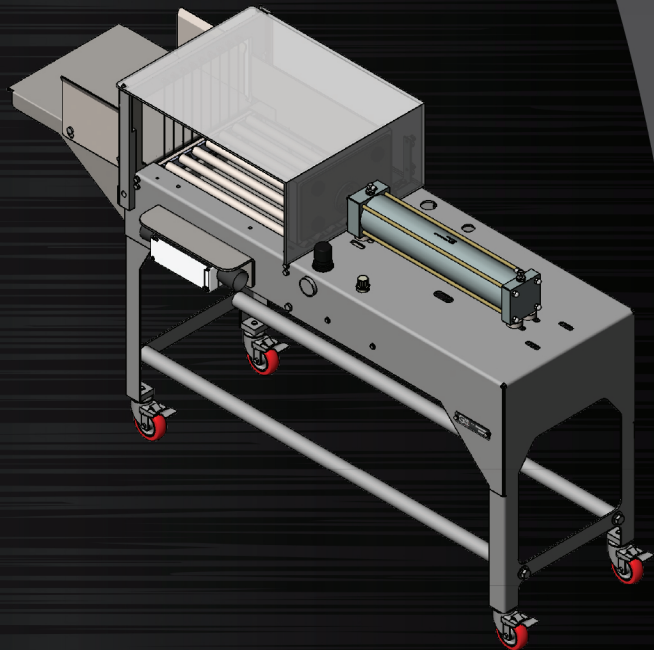
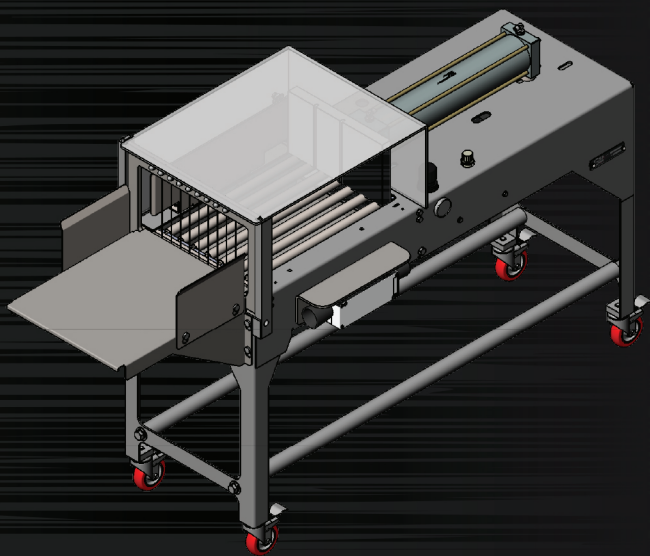

### Features:

- Cuts cheese blocks or other wire-cuttable products into uniform portions for retail purposes or further processing, such as dicing, shredding, melting, or blending
- Accurately portions a block size 14" x 11" x 7" using a grid harp pattern
- Harp is easily removed for cleaning and wire change
- Comes with an adjustable speed control
- 100% operated by air
- All stainless steel frame and manufactured parts
- Product load height and discharge are 35"
- Two-hand, anti-tie down control unit prevents operator interaction while the cutter is in motion. Pusher then returns to home position once released by operator.
- Machine footprint - 45" tall x 77" long x 25" wide



[WWW.GENMAC.COM](http://WWW.GENMAC.COM)